



TEST SIEVING MANUAL

A guide to the use, terminology and general information relative to test sieves and equipment for particle analysis.



Presented by
Endecotts Ltd, 9 Lombard Road, London SW19 3TZ England
Tel : +44 (0) 20 8542 8121 Fax : +44 (0) 02 8543 6629
E-mail: sales@endecotts.com www.endecotts.com

Contents

Preface

Section 1

1. Scope of Test Sieving

- 1.1 Particle size analysis
- 1.2 Advantages of sieving
- 1.3 Use of sieves
- 1.3.1 Major Industries using Test Sieves

Section 2

2. Terminology of Test Sieving

- 2.1 Material to be sieved
- 2.2 Test Sieves
- 2.3 Test sieving
- 2.4 Expression of results

Section 3

3. Standard Sieves

- 3.1 Woven wire sieves
- 3.2 Perforated plate sieves
- 3.3 Frame sizes
- 3.4 Fixed ratio apertures
- 3.5 Preferred number series
- 3.6 Standard sieve scales
- 3.7 Electroformed micro-sieves
- 3.8 Checking and calibrations of sieves
- 3.8.1 New sieves
- 3.8.2 Working sieves
- 3.8.3 Master sieves
- 3.9 Test sieves available from Endecotts

Section 4

4. Sampling

- 4.1 Gross samples
- 4.2 Laboratory and test samples
- 4.3 Test sample size

Section 5

5. Techniques of Test Sieving

- 5.1 Choice of sieve sizes
- 5.2 Preparation of sample
- 5.3 Methods of test sieving
- 5.3.1 Hand test sieving
- 5.3.2 Machine test sieving
- 5.3.3 Wet sieving
- 5.3.4 Combined wet and dry sieving
- 5.4 Cleaning and maintenance of sieves
- 5.5 Micro-sieving

Section 6

6. Data Analysis

- 6.1 Tabulation of data
- 6.2 Graphical methods
- 6.2.1 Ordinary or squared graph paper
- 6.2.2 Semi-log graph paper
- 6.2.3 Log-log graph paper
- 6.3 Fractional percentage graphs
- 6.4 Cumulative percentage graphs
- 6.5 Precision of weighing
- 6.6 Reproducibility

Section 7

7. Particle Size

- 7.1 Equivalent diameters
- 7.2 Powder types
- 7.3 Limiting mean size
- 7.4 Particle shape

Section 8

8. Industrial Screening

- 8.1 Sieving and screening
- 8.2 Screening efficiency
- 8.3 Sample calculation

Section 9

9. Specifications

- British standard sieve series
- American standard sieve series
- International test sieve series

Section 10

10. Tables of Useful Data

The International System of Units(SI)

- 10.1 The Basic SI Units
- 10.2 Some derived SI units having special names
- 10.3 Prefixes for unit multiples and sub-multiples
- 10.4 Conversion factors for some common units
- 10.5 Decimal inch equivalents of millimetres
- 10.6 Decimal and millimetre equivalents of fractional inches
- 10.7 Metric conversion factors for area
- 10.8 Principal series of preferred number

Preface

We present here a concise account of Test Sieves, what they are, what they do, how to use them and how to obtain the maximum amount of information from the resulting data.

As one of the largest manufacturers of Test Sieves in the world we have, over the years, compiled a considerable amount of valuable information on sieves and test sieving techniques. We decided to assemble some of this material and the result was our Manual of Test Sieving, first published in 1963 which proved to be a very popular publication. A revised version was published in 1970 under the title Test Sieve Data and further revised in 1977 under the title Test Sieving Manual.

In this new *Electronic Version* we have taken the opportunity of bringing the material up to date, particularly the sections dealing with standard sieve scales and test sieving procedures, and adding some extra material.

Once again we should like to express our gratitude to Professor J.W. Mullin, DSc, PhD, FEng, FRSC, FICHEM, of UCL, University of London, for editing this work.

This manual has been written for the ordinary user of Test Sieves, not for the specialist. For those who wish to delve deeper into the theories of sieving, sampling, analysis of data, etc., there are already several adequate accounts available in technical literature.

We hope you find this *Electronic Version* interesting and of some benefit. We do not claim that it is in any way comprehensive, so if you feel that we could have profitably included some particular topic, or enlarged upon one already dealt with, please let us know.



Section 1:

Scope of Test Sieving

1.1 Particle Size Analysis

A test sieve is an instrument which is used for the measurement of particle size. In its most common form it consists of a woven wire screen, with square apertures, rigidly mounted in a shallow cylindrical metal frame. For coarse sieving a perforated plate screen with square or round holes may be used in place of wire mesh. Square hole perforated plate sieves range down to 4mm and round hole sieves down to 1mm aperture.

The sizes of solid particles from 125mm down to 20 microns can be measured rapidly and efficiently by means of standard test sieve. Special sieves with apertures smaller than 20 microns are available, but it should be appreciated that the finer a screen is, the more easily will certain types of particulate solids tend to block or blind the apertures. Nevertheless, 'micro' sieving can be carried out down to 5 microns using special techniques.

Particle size, as measured by test sieving, may be specified simply by quoting two sieve sizes, one through which the particles have passed, and the other on which they are retained. However, the most frequent use of test sieving is for measuring the size spread, i.e., the particle size distribution.

Test sieving is not the only method available for particle size analysis, but it is certainly the most widely used and probably the most important. A short list of some of the more common methods, together with their effective size ranges, is given in Table 1.1.

Table 1.1 Some Methods of Particle Size Analysis

Method	Approximate Useful Range (microns)
Test sieving	125,000-5
Air elutriation	50-5
Optical Microscopy	150-0.25
Liquid sedimentation (gravity)	50-1
Liquid sedimentation (centrifugal)	5-0.05
Microscopy	1-0.005
Electrical sensing zone (Coulter)	200-1
Laser light scattering (Fraunhofer)	1000-0.1

In Table 1.1 two very important characteristics of test sieving are clearly seen. First, it covers a very wide range of particle size (from 125mm, i.e., 125,000 microns, down to 5 microns) and this range is the one which happens to be of considerable industrial importance. Secondly, it meets little or no serious competition from the other methods.

1.2 Advantages of Sieving

Perhaps the biggest advantage of test sieving is that it so frequently happens to be the only suitable method of size analysis for a particular purpose. However, even when there is a choice of method, test sieving generally proves to be the most convenient one.

It is a quick and reliable method of size analysis, equally suited to accurate scientific research work or routine analysis under industrial conditions. Tests can be performed at almost any location.

No complicated apparatus is demanded. A nest of sieves and a simple laboratory balance will suffice in most cases. In fact, rapid size checks can often be made on-site at a particular plant with the aid of a rough pair of scales.

The technique of test sieving is basically simple. No specialised knowledge or skill is needed; care and diligence are the main requirements. Process operators can easily be trained to carry out sieve tests.

When the size distribution of a sample has been determined by test sieving, the material becomes separated into several fractions. This is another important attribute. These fractions are not contaminated, nor have their chemical or physical properties been altered. They are, therefore, available for further inspection or independent analysis if required.

1.3 Use of Sieves

Wherever solid materials are handled or processed, test sieves find application. In laboratory or plant these simple precision instruments are invaluable.

Test sieves are used, for example, by chemists and pharmacists, physicists and geologists, chemical and civil engineers, mining and metallurgical engineers,

A further list maybe found in 1.3.1

The uses to which test sieves are put are as many and varied as the types of people who use them. Most solid raw materials and finished product specifications contain a clause which stipulates the range of the size spread or the maximum or minimum size in terms of some standard sieve series.

Some typical applications are as follows: the sizing of chemical and pharmaceutical crystals and powders; the grading of coal and ores; determining the efficiency of a crusher; grinder or industrial screening unit; cement testing; classifying silt, soil, sand, gravel and other materials encountered in civil engineering work; checking the state of a fluidised catalyst in an oil refinery.

The above examples are but a few of the thousand and one uses to which test sieves are known to have been put.

1.3.1 Major Industries using Test Sieves

Construction:	Quality Control Analysis & Grading of Soils, Aggregate, Minerals, Cement etc
Laboratories:	Miscellaneous application of particle analysis and determination of particle size.
Mining:	Quarries (Gravel & Sand), Coal Mines (Air pollution control), grading and particle size determination. Diamond Mines (Grading Diamonds).
Chemical:	Oil Exploration (analysis of minute fossils), Fuels, Explosives, Drugs Medical and Pharmaceutical applications.
Agriculture/Food:	Confectionery and Food Manufacture, Miscellaneous Applications including particle sizing of Grain.
Education:	Schools, Universities (training of techniques in particle size analysis and determination of particle size).
Research:	Research establishments engaged in original and general research. Various applications,
Engineering:	Steel Manufacturing organizations, Foundries, Iron Works etc., (Determination of particle size of sand moulds, grading of coke etc.,)

Section 2:

Terminology of Test Sieving

Test Sieving, using woven wire or perforated plate sieves, has its own special terminology which has been agreed internationally (ISO 2395 'Test sieves and test sieving-vocabulary'). This useful information is given below:

2.1 Material to be Sieved

Particle	A discrete element of the material regardless of its size.
Agglomerate	Several particles adhering together.
Sample	A representative part taken from a quantity of material.
Test sample	The sample which is used in the test.
Charge	A test sample, or part of a test sample, placed on a test sieve or a nest of sieves.

Apparent bulk density The mass of the charge divided by volume at the moment when it is placed on the sieving medium.

2.2 Test Sieves

Sieving medium	A surface containing regularly arranged apertures of uniform shape and size.
Sieve	An apparatus for the purpose of sieving, consisting of a sieving medium mounted in a frame.
Test Sieve	A sieve, intended for the particle size analysis of the material to be sieved, which conforms to a test sieve standard specification.
Certified test sieve	A test sieve that has been examined and certified, by an authority accredited for the purpose, as complying with an agreed specification.
Matched test sieve	A test sieve that reproduces the results of another test sieve within defined limits for a given material.
Full set of test sieves	All the test sieves of a given sieving medium contained in a standard specification.
Regular set of test	A number of sieves taken in regular order from a full set of test sieves, for a particle size analysis.
Irregular set of test sieves	A number of sieves taken in irregular order from a full set of test sieves, for a particle size analysis.
Nest of test sieves	A set (regular or irregular) of test sieves assembled together with a lid (cover) and receiver (pan).
Frame	A rigid framework which supports the sieving medium and limits the spread of the material being sieved.
Lid (cover)	A cover which fits snugly over a sieve to prevent escape of the material being sieved.
Receiver (pan)	A pan which fits snugly beneath a sieve to receive the whole of the passing fraction.
Aperture size	Dimension defining an opening.
Percentage sieving area	Ratio of the area of the apertures to the total area of sieving medium, as a percentage.

Woven wire cloth	A sieving medium of wires which cross each other to form the apertures.
Wire diameter	Diameter of the wire in the woven cloth.
Warp	All wires running lengthwise of the cloth as woven.
Weft (shoot)	All wires running crosswise of the cloth as woven.
Type of weave	The way in which warp and weft wires cross each other.
Plain weave	Weave in which every warp wire crosses alternately above and below every weft wire and vice versa. (see Figure 2.1a)

Twilled weave Weave in which every warp wire crosses alternately above and below every second weft wire and vice versa. (see Figure 2.1b)

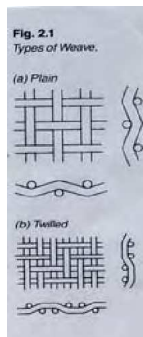

Perforated plate A sieving medium consisting of a plate with uniform holes in symmetrical arrangement.

Pitch (centres)	Distance between corresponding points of two adjacent holes in a perforated plate.
Bridge width (bar)	Distance between the nearest edges of two adjacent holes in a perforated plate.
Margin	Distance between the outside edges of the outside rows of holes and the edges of a perforated plate.
Plate thickness	Thickness of the plate after perforation.
Punch side	The surface of a perforated plate which the punch entered during the perforating operation.

2.3 Test Sieving

Sieving	The process of separating a mixture of particles according to their size by means of one or more sieves.
Test sieving	Sieving with one or more test sieves.
Dry sieving	Sieving in the absence of a liquid.
Wet sieving	Sieving in the presence of a liquid.
Sieving rate	Quantity of material, expressed either in units of mass or as a percentage of the charge, passing through a sieve in a given interval of time.

Undersize (fines) That portion of the charge which has passed through the apertures of a stated sieve.

Oversize (residue) That portion of the charge which has not passed through the apertures of a stated sieve.

End Point The point in time after which further sieving fails to pass an amount sufficient to change the result significantly. The end point should be specified in particular standards for each product in terms of the sieving rate, clarity of liquid in wet sieving, or other measurable criterion.

Near-size particle Particle of size approximately equal to the sieve aperture.

Blinding Obstruction of the apertures of a sieving medium by particles of material being sieved.

2.4 Expression of Results

Particle size (sieve size of a particle) The smallest sieve aperture through which a particle will pass if presented in the most favourable attitude.

Size analysis by sieving The division of a sample by sieving into size fractions, and the reporting results.

Size distribution curve A graphical representation of the results of a size analysis.

Cumulative oversize distribution curve A curve obtained by plotting the total percentages by mass retained on each of a set of sieves of descending aperture size against the corresponding aperture sizes.

Cumulative oversize distribution curve A curve obtained by plotting the total percentages by mass passing on each of a set of sieves of descending aperture size against the corresponding aperture sizes.



Section 3:

Standard Sieves

3.1 Woven Wire Sieves

The two fundamental dimensions of the wire cloth in a test sieve are the thickness (diameter) and spacing of the wires. These factors govern the open area and the aperture width. The former quantity determines the capacity of the sieve, or the rate of sieving, while the latter gives the measure of the particle size.

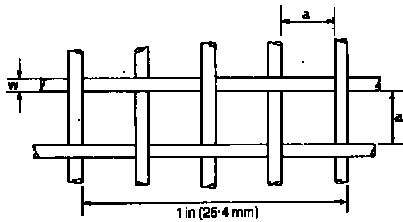

Fig 3.1 Dimensions of wire cloth: wire diameter, *w*, aperture width, *a*, and mesh number, *M*. (Here *M* = 4)

Woven wire cloth is frequently designated by a mesh number defined as the number of wires per inch (25.4mm), which is the same thing as the number of square apertures per inch (see Figure 3.1).

The aperture width, *a*, wire diameter, *w*, mesh number, *M*, and open area, *A*, are inter-related by the following equations:

$$M = \frac{1}{a + w} \dots\dots\dots (1)$$

$$a = \frac{1}{M} - w \dots\dots\dots (2)$$

$$A = \frac{a^2}{(a + w)^2} = (Ma)^2 \dots\dots\dots (3)$$

An example of the use of these equations may be given by the following simple calculations based on a 100 mesh wire cloth with 0.1mm diameter wires.

$$100 \text{ mesh} = 100 \text{ apertures per inch (25.4mm)} = 3.94 \text{ apertures per millimetre}$$

Equation 2 gives the aperture width:

$$a = \frac{1}{3.94} - 0.1 = 0.15\text{mm}$$

Equation 3 gives the open area:

$$A = (3.94 \times 0.15)^2 = 0.35 \text{ or } 35\%$$

The following method may be adopted for identifying a piece of wire cloth by mesh count. The number of apertures or wires chosen for counting depends on the fineness of the cloth. For example, 10 apertures would be sufficient for apertures of about 1mm, 50 would be necessary for about 0.1mm and 100 for about 0.05mm.

The method is as follows:

- (1) Count off a convenient number of apertures (or wires) *N*.
- (2) Measure the length *L* (mm) covered by *N* apertures (or *N* wires).
- (3) Measure the wire diameter, *w* (mm)

The nominal aperture width, *a* (mm) is then given by

$$a = \frac{L}{N} - w \dots\dots\dots (4)$$

Example:

Apertures (or wires) counted,	<i>N</i> = 10
Length covered by 10 apertures,	<i>L</i> = 21 mm
Diameter of a single wire,	<i>w</i> = 0.5mm
Nominal aperture width,	<i>a</i> = 1.6 mm

The above wire cloth is therefore identified as 1.6mm aperture width with 0.5 mm diameter wires.

The mesh count may be calculated as 25.4 *N*/*L* per inch (25.4 mm) or 10/*NL* per centimetre (10mm). Thus for this example the mesh counts of the wire cloth are 12.1 per 25.4 mm and 4.8 per 10 mm.

Wire diameters are best measured with a micrometer calliper. Mesh counts of the finer cloths have to be made with the aid of a magnifying glass, preferably of a type which views the wire mesh as a background to a glass measuring scale.

Although mesh number designations have been deleted from most National and International standard specifications for test sieving (see Section 9), the wire weaving industry is reluctant to dispense with them altogether because mesh count is a very convenient way of making a rapid identification of wire mesh.

Nevertheless, the use of mesh numbers to designate woven wire test sieve aperture sizes, and consequently to classify the size of particles passing through them, cannot be recommended. As can be seen from Equation 1, the mesh number *M* is a function of both aperture width *a*, and wire diameter *w*, but some standard sieve scales permit slightly different wire diameters for particular aperture sizes and this can cause confusion.



Table 3.1 Comparison between the British and US standard wire mesh sieve scales* showing the potential confusion of using the 'mesh number' as sieve designation

Aperture width μ			Aperture width μ		
Mesh number †	BS	ASTM	Mesh number †	BS	ASTM
(obsolete)	410	E11	(obsolete)	410	E11
3	5600		50		300
3½	4750	5600	52	300	
4	4000	4750	60	250	250
5	3350	4000	70		212
6	2800	3350	72	212	
7	2360	2800	80		180
8	2000	2360	85	180	
10	1700	2000	100	150	150
12	1400	1700	120	125	125
14	1180	1400	140		106
16	1000	1180	150	106	
18	850	1000	170	90	90
20		850	200	75	75
22	710		230		63
25	600	710	240	63	
30	500	600	270		53
35		500	300	53	
36	425		325		45
40		425	350	45	
44	355		400	38	38
45		355	450	32	32

*Both standard test sieve scales BS410 and ASTM E 11 are compatible with the international (ISO 565) scale.

3.2 Perforated Plate Sieves

For aperture sizes 1 mm and larger, perforated plate sieves are available in addition to the woven wire series. British Standard BS 410 : 1986 for example, lists series of round hole and square hole perforated plate sieves.

The arrangement of holes in perforated plate sieves is shown in Section 2. The square holes are arranged in line with the centre points at the vertices of the squares. The round holes are arranged with the centres at the apices of equilateral triangles.

The percentage open area (sieving area) of a perforated plate sieve can be calculated from the relationships:

$$A = \frac{a^2 \times 100}{p^2} \text{ for square holes}$$

and

$$A = \frac{a^2 \times 90.7}{p^2} \text{ for round holes}$$

where p is the pitch of the holes (see Figure 3.2).

Perforated plate sieves with slotted apertures are available for special purposes. For example, ISO 5223 (Test sieves for cereals) specifies 20mm long apertures with rounded ends and a range of widths from 1 to 3.55mm.

Robust stainless steel Grid Sieves, for flakiness testing of aggregates, with slot widths ranging from 40.0 to 2.5mm are specified in Euronorm EN 933-31:1997.

3.3 Frame Sizes

The most common size of frame for a fine mesh test sieve is 200mm diameter. Although for certain purposes, e.g. the sieving of small samples, 100mm diameter frames may be used. For sieve apertures of 1.0mm and larger, 300mm diameter frames may be specified while 300mm and 450mm diameter frames can be used for coarse sieves up to 125mm aperture.

It should be noted that it is still common practice in the USA to use 8 in. (203mm), 12 in. (305mm) and 18 in. (457mm) diameter sieve frames (US Standard ASTM E11) instead of the 200, 300 and 450mm sizes specified in the other national and international standards. Other diameters are also permissible by the ISO 3310 & ASTM specifications. The depth of the sieve frames can vary according to the frame diameter. In addition most sieves can be obtained with 'half-height' frames.

3.4 Fixed Ratio Apertures

For size testing purposes it is desirable to have a set of sieves in which the screen apertures bear some sort of relationship to one another. As early as 1867 Rittinger, in his work on ore dressing, had suggested that a useful sieve scale would be one in which the ratio of the aperture widths of adjacent sieves was the square root of two ($\sqrt{2} = 1.4142$).

There are many advantages of a $\sqrt{2}$ series of sieves. For instance, the aperture areas double at each sieve, proceeding from the fine to the coarse end of the scale i.e. the aperture widths double at every other sieve in the series. Furthermore, by omitting certain sieves in the range, it is possible to get other sequences.

It was later recognised, particularly by Richards and Disbro in the United States, that a better sieve scale would be one based on a fourth root of two ratio ($\sqrt[4]{2} = 1.892$) in other words a second $\sqrt{2}$ series of sieves inserted between the first $\sqrt{2}$ series. In this way a much closer sizing of the particles is possible.

On the continent of Europe, metric scales of aperture sizes were generally based on roots of ten, which possess similar properties to those described in the Section 3.5

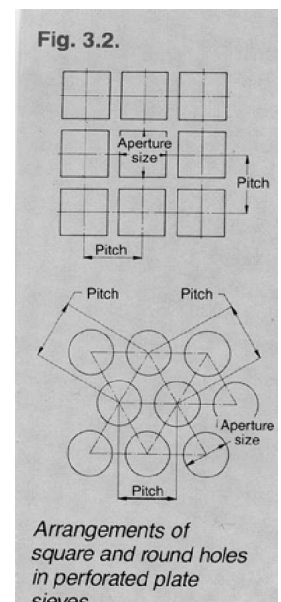

3.5 Preferred Number Series

Number series based on roots of ten are called Preferred or R(enard) numbers, named after Col. Charles Renard, an officer in the French Engineer Corps., who first proposed their use for military purposes in 1879. Series based on the tenth, twentieth and fortieth roots of ten, for example, are called R10, R20 and R40 series of preferred numbers respectively (see Table 10.9).

One of the most useful properties of a preferred number series arises from the fact that the tenth root to ten (1.2589, only differs by less than 0.1% from the cube root of two (1.2599). Thus (see Table 10.9) every third number in the R10 series (designated for convenience as R10/3) has a step ratio of two, i.e., a 100% increment

3.6 Standard Sieve Scales

The R40 series has found application in the international standardisation of test sieves because every third R40 number, i.e. R40/3 series, has a step ratio of 1.1885 which corresponds very closely to the fourth root of two (1.1892). It has thus been possible to find common ground between the various national standards such as the British (BS) American (ASTM), German (DIN) and French (AFNOR). International discussions on the subject of test sieves and test sieving are organised by the ISO Committee TC24 (Sieves, sieving and other sizing methods). The International Standards ISO 565 (1983) (Test Sieves – woven metal wire cloth and perforated plate – nominal sizes of apertures) and ISO 3310 (2000) (Test sieves – technical requirements and testing: Part 1 - metal wire cloth, Part 2 – metal perforated plate) contain two tables, each of which gives a series of 24 principal sizes (R20/3), based on a module of 1.0mm

Two series of supplementary sizes are also included: the first belongs to the R20 series, while the second is taken from the R40/3 series. The approximate ratios of successive sizes in these series are: R20/3 – 1.4 (i.e., 40%) R40/3 – 1.19 (19%) R20 – 1.12 (12%). These International Standards make provision for aperture sizes in woven wire cloth test sieves down to 20µm, although all apertures below 45µm are regarded as supplementary.

It is recommended that the ISO principal sizes should be used where possible, but if a closer series is required it should be drawn from one of the alternative supplementary series R20 or R40/3, but not from both.

BS 410 takes into account the latest ISO TC24 recommendations embodied in ISO 565. A basic R40/3 series of apertures is specified with a ratio of successive sizes of about 1.19. The wire mesh series has been extended to include apertures in the full range of 125mm to 20µm, while the perforated plate series covers the range 125mm to 4mm (round and square holes) and to 1mm (round hole only).

In addition to the basic R40/3 sizes an additional series covering the full R20 list of sizes is also included in BS410 (which is now dual numbered with ISO 3310). In both series the principal (R20/3) sizes specified in the International Standard ISO 565 are marked with an asterisk. It is recommended that these sizes should be the first choice when selecting a nest of sieves. Additional sizes from either series can then be selected as required.

3.7 Electroformed Micro Sieves

Standard Test Sieves, i.e., sieves with apertures conforming to specified tolerances are not available with aperture sizes smaller than 20 microns, yet particle size analysis by test sieving is frequently required for particles smaller than this. For very fine size grading, special sieves are now available with the sieving surface made from accurately electroformed nickel plate (micro plate). These special sieves, specified in Part 3 of ISO 3310 (Test sieves of electroformed sheets), are available in 100mm and 200mm frames with a wide range of aperture sizes from 500 down to 5 microns. Tolerances for apertures larger than 36 microns are +/- 2 microns.

Techniques for the use of micro-sieves are described in Section 5.5.

3.8 Checking and Calibration of Sieves

3.8.1 New Sieves

Endecotts test sieves fully comply with an appropriate National or International Standard Specification. Each sieve is permanently labelled as conforming to a particular Standard and is supplied with an appropriate compliance certificate and record card. The record card should be retained throughout the working life of the sieve and used to maintain in-house records of sieve examinations.

Measurement for compliance with a test sieve specification is made by optical projection, co-ordinate measuring machines or similar equipment, using procedures described in the relevant specification. *Endecotts* guarantee to supply sieves complying with an appropriate Standard.

Each sieve is marked with an individual serial number making it traceable to its manufacture.

Users should ensure that all sieve sets are marked, or colour coded, as a means of identification.

3.8.2 Working Sieves

Visual Inspections

All sieves should be checked visually by the operator before each use. Confirmation that this check has been made should be recorded with all measured test data.

A detailed check should be made of the condition of every sieve at regular intervals, depending on the frequency of use, and the result noted on the sieve record card.

The visual check should identify any damage, scoring or blinding, which is likely to affect the performance of the sieve. If any doubt exists, a measurement or performance check, as appropriate, should be carried out before further use.

The apertures of all test sieves should be checked at regular intervals, depending on the frequency of use, by the procedures outlined below using a suitable reference sample. Records should be kept of all checks made.

Certified reference samples

A certified reference sample consisting of uniformly graded, rounded or sub-rounded particles, of known particle size distribution, and of a size such that approximately 50% is retained on the sieve being checked, may be used to check each working sieve.

A certified reference sample should not be used for more than one determination, unless permitted by the certification body responsible for the reference sample.

Performance check samples

Performance check samples, consisting preferably of rounded or sub-rounded particles, should be created for each sieve size to be checked. The mass of the performance check sample should be selected so as not to exceed the maximum retained mass recommended in any relevant test procedure or specification, e.g., see Table 4.1 The performance check sample should be uniformly graded and should comply with the following:

<u>Test sieve aperture size</u>	<u>a</u>	<u>% passing</u>
The nearest size above	2a	100
Size	a	40 to 60
The nearest size below	0.5a	less than 5

Alternatively, particles of material similar to that routinely sieved by the user may be employed to create performance check samples, provided no significant attrition of the particles occurs during the sieving procedure.

3.8.3 Master Sieves

For each working sieve the user should keep an associated master sieve of the same diameter, nominal aperture size and type of weave. The master sieve should be retained exclusively for use as a master sieve until its replacement is due, say after fifty uses or five years depending upon which is reached first.

Performance check procedure

The performance check procedure should be to dry-sieve a performance check sample first through the master sieve and then through the new working sieve for a controlled period.

The performance check sample may be retained for further use provided no significant attrition and/or loss of particles occurs.

A sieve may be considered as passing the performance check when the change in mass of material passing through the sieve since its first use does not exceed a specified tolerance, depending on the accuracy requirements of the test method for which the sieves are used. Where no standard requirements for accuracy are available this tolerance may be assumed to be 5%.

Working sieves may also be checked in sets using an appropriate performance check sample.

The performance check procedure monitors the rate of wear of the test sieve to ensure that it is consistent with the manufacturing tolerances for the test sieve and the requirements of the tests in which it is used.

The useful life of a working sieve is very dependent on the manner of its use and the abrasiveness of the materials being tested. Until such time that a laboratory has sufficient records to indicate rates of wear on the working sieve, enabling it to assign rational check periods, performance checks should be carried out at intervals of not more than three months.

Identification of Failures

Test sieves which fail visual examination or optical measurement checks should be clearly identified as such and either discarded or used only as protection sieves where appropriate.

Procedures and Records

Laboratories should have a written procedure for the visual inspection, performance checking and, if appropriate, optical measurement of test sieves and should maintain records of all examinations made.

NOTE: These guidelines are based in part on the UKAS “Traceability: Test Sieves” publication ref: LAB22 (Edition 1 11/00)Published by UKAS 21-47 High Street, Feltham TW13 4UN UK. www.ukas.com (Information Centre)

3.9 Test Sieves available from Endecotts

Laboratory Test Sieves

All test sieves manufactured to a National or International Specification are supplied with a Certificate of Compliance, and are individually serial numbered giving full traceability.

Inspected Test Sieves

Test sieves inspected in accordance with the procedures listed in clause 5.2 and table 4 column 2 of ISO 3310 (BS:410). Each sieve is supplied with an Inspection Certificate stating separately the values for the average aperture size in both the warp and weft directions of the wire cloth.

Calibrated Test Sieves

Test sieves inspected and calibrated in accordance with the procedures listed in clause 5.2 and table 4 column 3 of ISO 3310 (BS:410). Each sieve is supplied with a Calibration Certificate recording the number of apertures and wire diameters measured, the average aperture size and standard deviation separately for the warp and weft directions. The type of weave will also be stated.

Matched Test Sieves

Two or more test sieves each fitted with a sieving medium having similar aperture characteristics. Each sieve is supplied with a Calibration Certificate marked 'matched with sieve serial no.....'

Mid-Point Test Sieves

Test sieves with the sieving medium specification tolerances reduced by 30%. Each sieve is supplied with a Calibration Certificate giving the range of tolerances and measurements taken.

Re-Examination Service

Used sieves are examined and inspected in accordance with the appropriate specification. Complying sieves are issued with a Compliance, Inspection or Calibration Certificate, as requested by the Customer.

Section 4: Sampling

Efficient sampling is a task which must be performed conscientiously. A sample should represent the bulk quantity of material as closely as possible, otherwise any subsequent analysis carried out on the sample will at best be an utter waste of time, and at worst grossly misleading.

Usually there are two main stages in any sampling scheme. First, a gross sample which represents the parent lot is collected, and secondly a representative laboratory sample is prepared from the gross sample. These two operations generally demand different techniques. Gross samples can range up to 50 kg or more, depending on the size of the bulk quantity, while laboratory samples rarely exceed 1 or 2 kg.

A third sampling operation is generally performed in the laboratory, viz. the preparation of one or more small test samples from the larger laboratory sample.

4.1 Gross Samples

Segregation is one of the main troubles encountered in the sampling of solid particles. In conical heaps of material, for instance, a large proportion of the coarser particles will generally be found in the lower levels of the pile. On the other hand, coarse particles tend to migrate towards the top of the contents of a container, especially after transportation. The chosen sampling technique must allow for these irregularities.

Grab sampling with scoops or shovels is quite a popular method of obtaining bulk samples. For example, a large number of random samples may be taken from a heap of the material, or regular samples (e.g. every *n*th shovelful) can be scooped into a sample container when the bulk material is being transferred manually from one location to another. Regular sampling is most often favoured from materials packed in containers ; for example, every *n*th package in each row or stack could be selected. A common sampling device for this purpose is the "thief", various types of which are available. In its simplest form the sample thief consists of a piece of metal tubing with a sharp bottom edge. It is pushed gently, firmly and vertically into the full depth of the material. It is then withdrawn and the sample is removed. The use of a thief tends to minimize the effects of segregation, but when excessive segregation has occurred the material should be re-mixed before sampling.

For material flowing down chutes or from hoppers, a sample collector may be placed in the path of the outlet stream at regular time intervals. Here again, precautions must be taken against segregation. For example, the collector should sample the whole of the outflowing stream, and it should never be permitted to overflow because coarse particles tend to roll off the heap leaving behind an excessive proportion of fines.

4.2 Laboratory and Test Samples

Gross samples can be sub-divided into one or more smaller samples by hand or mechanically. The most common hand method is that known as 'coning and quartering'. This is best done on a flat clean surface. e.g. a concrete yard for large samples or a sheet of glossy paper for laboratory work. The method is as follows.

Mix the gross sample and pile it into a conical heap. Flatten the cone to about one quarter of its original height. Divide the flattened heap into four equal quarters – this can be done with a sharp-edged wooden or metal cross which is pressed into the heap. Reject two of the opposite quarters and mix the remaining pair. Pile these into a conical heap and repeat the above procedure until the required sample quantity is obtained. Figure 4.1 demonstrates the various stages.

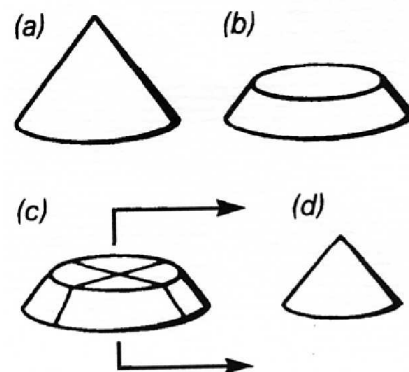

Fig. 4.1 Coning and quartering (a) original sample in a conical heap, (b) flattened heap, (c) quartered heap, (d) two opposite quarters mixed and piled into a conical heap.

Several types of mechanical sample divider have been described in British Standard BS 5309 (1976) (Methods for sampling chemical products. Part 4 – sampling of solids). One such sample divider, the riffle, manufactured by Endecotts, is a box with an open top divided into a number of compartments with their bottoms sloping towards opposite sides of the box. When a quantity of material is poured evenly into the hopper, it is split into equal portions. The principle of sample splitting is shown in Figure 4.2 where the halving of some quantity, Q , at each stage of a battery of riffles of decreasing size can be clearly seen.

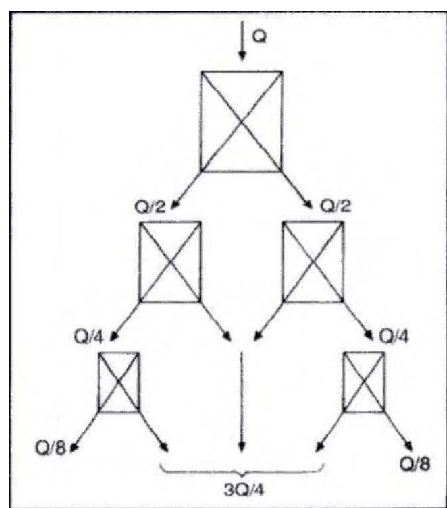

Fig 4.2 *The Principle of Sample Splitting*

A gross sample, or a laboratory sample obtained by any of the above methods, may require further reductions into several equal portions for separate analysis. This can be done as follows. Suppose four equal analysis samples are required, then four tins are placed in a row, a scoop full of the material is taken and, as near as can be judged, one quarter of it is put in each tin. This is repeated, filling the tins in the sequence:

1 st scoopful	1,2,3,4
2 nd scoopful	2,3,4,1
3 rd scoopful	3,4,1,2

In this manner no tin is filled exclusively from one particular part of the scoop.

Many books have been written about the statistical theories of sampling, and comprehensive accounts of sampling techniques are given in several BS specifications. Useful introductions to the subject are given in the 4-part BS 5309 (1976) (Methods for sampling chemical products) and in BS 812 (1984) (Testing aggregates: Part 102 – Methods for sampling) and in BS 3406 (1986) (Determination of particle size distribution: Part 1 – Guide to powder sampling).

4.3 Test Sample Size

The size of a test sample for test sieving is largely governed by the density and size distribution of the particles. There are of course other factors to consider. Very small samples may not be truly representative of the bulk material, and errors in the collection and weighing of the fractions may be serious. Very large samples are usually inconvenient to

handle; they may take too long to sieve and the excessive weight can easily damage the sieving surface.

The optimum sample size can only be found from experience, but the following rough guide may be found useful.

For example, the test sample size for 200 mm (8in) diameter sieves can be based on the density of the solid particles:

Density:	1.5	1.5-3.0	3.0 (g/cm ³)
Sample Mass:	25	50	100(g)

For sieves of diameter other than 200mm, these values should be modified accordingly. Alternatively, the test sample size can be based on the median particle size (see Section 7.3) of the material to be sieved. Again for a 200mm diameter sieve:

Median Size	Sample Mass (g)
>2mm	500
2-1mm	200
1-0.5mm	100
500-250µm	75
250-75µm	50
<75µm	25

A more accurate way of arriving at the test sample size is indicated in Table 4.1. The quantity of material to be placed on a sieve (the charge) for testing purposes depends on the size of the sieve aperture, the cross-sectional area of the sieve and the bulk density of the material. Table 4.1 gives a guide to the quantities of material to be placed on a sieve for a sieve test. Column 2 gives values of the volume of the sieve charge. Column 3 gives maximum volumes of material permitted on the sieve after the completion of sieving. The volume of material placed on a given sieve should be such that the volume retained is not greater than the quantity recorded in Column 3. It may be necessary, therefore, to sieve a test sample in two or more portions (charges) to avoid overloading the sieve. The results of the tests can afterwards be combined.

The values of the quantities in Table 4.1 refer to a 200mm (8in) diameter sieve. When using test sieves of other sizes and shapes the values in Table 4.1 should be modified accordingly.



The sample quantities recommended in Column 2 of Table 4.1 will also apply to nests of sieves and to machine sieving.

Table 4.1 Quantity of material for test sieving on 200mm round sieves.

1	2	3
Nominal width of aperture	Volume of Material	
	Recommended volume of material test sample	Maximum volume of residue permitted on the sieve at the completion of sieving
mm	cm ³	cm ³
22.4	1600	800
16.0	1000	500
11.2	800	400
8.0	500	250
5.6	40	200
4.0	350	175
2.8	240	120
2.0	200	100
1.4	160	80
1.0	140	70
microns		
710	120	60
500	100	50
355	80	40
250	70	35
180	60	30
125	50	25
90	42	21
63	35	17
45	30	15
32	26	13
20	20	10

The recommended test sample mass (g) is calculated by multiplying the volume quantity (cm³) in Column 2 by the apparent bulk density (g/cm³) of the material to be sieved. To avoid overloading the sieve, the test sample will have to be divided into two or more charges if the quantity of material remaining on the sieve at the end of the sieving process exceeds the quantity stated in Column 3.

As a guide, the rule would be to use the sample quantity recommended in Column 2 for the sieve with the largest aperture in the set provided that the particle size distribution of the sample does not cause overloading of any of the finer aperture sieves in the set, as indicated by the values in Column 3.

For best results it is always better to underload the coarser sieves to avoid overloading any of the finer sieves of the nest.

Particle shape may also have to be taken into account in selecting the test sample size. Flaky or needle-shaped substances, for instance, are more difficult to sieve than granular particles. The sample mass should be reduced when 'difficult' materials are being tested.

Samples of materials which have a narrow range of particle size should be kept small to avoid overloading on the sieves. Samples containing quantities of dust may be pre-sieved before testing (see Section 5.3.1).

To avoid damage to a test sieve the size of the largest particle in the charge should have a definite relation to the nominal sieve aperture size (a). The approximate maximum particle size (mm) is $10a^{0.7}$ where (a) is also in millimetres.

For example:

Nominal Aperture Size a	Approximate Size of Largest Particle (mm)
25mm	95
4mm	26
1mm	10
250µm	3.8
45µm	1.2

Section 5:

Techniques of Test Sieving

5.1 Choice of Sieve Sizes

For most size analyses it is usually impracticable, and indeed quite unnecessary, to use all the available screens in any Standard Sieve Series. However, the best number of sieves to use in a given test can present a problem.

Broadly speaking, if sieves in the mid- range of a given series are employed, not more than about 5% of the sample should pass the finest sieve or be retained on the coarsest. For detailed work these limited may be lowered. Once the top and bottom sieves have been decided upon, the intermediate sieves can then be chosen.

For many purposes, alternate sieves in the range are quite adequate. Over certain size ranges of particular interest, or for accurate work, consecutive sieves may be used. The intermediate sieves should never be chosen at random.

The following four examples indicate some of the choices that could be made from BS sieves in the range 710-180µm:

- (a) 710 600 500 425 355 300 250 212 180
- (b) 710 500 355 250 180
- (c) 710 500 425 355 300 250 180
- (d) 710 600 300 212 180

(a) Consecutive sieves which obey the R40/3, (approx $\sqrt[4]{2}$) relationship. Necessary only for detailed size analysis over the whole range.

(b) Alternate sieves which obey the R20/3, (approx $\sqrt{2}$) relationship. Adequate for most purposes.

(c) Combination of the R40/3 and R20/3 ($\sqrt{2}$ and $^4\sqrt{2}$) series. Useful if a detailed analysis is required over part of the range.

(d) Bad choice. Random selection. Difficult to interpret data either in tabular form or graphically (see Section 6).

5.2 Preparation of Sample

The subject of sampling was dealt with in the previous section. The main points to note are that the test sample, which must be representative of the material to be tested, may have to be split into several portions (charges) for sieving in order to avoid overloading the sieves (see Table 4.1)

The mass of the sample must not be allowed to change during the test. Damp materials should be dried, in an oven if necessary, but care must be taken not to alter the physical characteristics of the material. If the material has been heated in an oven it should be cooled in the atmosphere before the test. Samples of hygroscopic solids should be oven-dried, cooled in a desiccator, and then sieved with the minimum amount of exposure to the atmosphere. If there is a change in moisture content during the test, the masses of the charges and the sieve fractions should be corrected to their dry masses.

5.3 Methods of Test Sieving

British Standard BS 1796 (1976) (Method for test sieving) and International Standard ISO 2591 (1972) (Test Sieving) are largely devoted to the specification of general procedures for test sieving, and reference should be made to these publications for a complete account of the subject.

No single method can be rigidly specified for the testing of all materials. Some solids are easy to sieve: some are very difficult and demand special techniques.

Sieve tests can be carried out by hand or on a machine designed to impart the necessary shaking, rotating, vibrating or jolting motion to the material on the screens.

In general, the mechanical method of testing has many advantages over the hand method. Reproducible results are usually obtained in a much shorter time mechanically, with a much lower expenditure of human effort. Recommended methods for both hand and machine sieving are summarized below.

5.3.1 Hand Test Sieving

The chosen nest of sieves (Section 5.1) is assembled with the coarsest mesh at the top, the finest mesh at the bottom and mounted on a receiver pan. The amount of test sample is selected in accordance with the procedures outlined in Section 4.3 and weighed with a precision of $\pm 1\%$. The charge to the top sieve can consist of the whole test sample except when the limits expressed in column 3 on Table 4.1

are exceeded. In such cases the test sample is divided into two or more charges, each one being tested separately. The results can afterwards be combined.

The nest of sieves, fitted with a lid if dusty material is being tested, is cradled loosely in a slightly inclined position in the crook of the arm and tapped at the rate of approximately 120 times per minute with the flat of the hand. After about 30 taps, i.e., four times a minute, the sieves are put into a horizontal position, turned through 90° and given a sharp vertical shake and a hard tap. The sieving time depends on a variety of factors such as the characteristics of the material (particle size, size distribution, shape, density, etc.) sieve size, volume of the charge, sieving intensity, humidity of the air, and so on.

Sieving like any other separation process, does not produce an ideal separation. A few particles which are smaller than the nominal aperture size always remain in the sieve residue, for example, by sticking to larger particles, because they have not found a free aperture or have only encountered undersize apertures, particles which are larger than the nominal aperture size are to be found in the passing fraction. Because of these imprecisions, the end-point of the sieving process has to be based on experience with the material being sieved.

For most non-friable materials, the end-point of the sieving process may be taken when the quantity passing through the sieve in 1 minute is less than 0.1% of the charge, if no other instructions are given. For friable materials and certain special cases, the end-point of the sieving process has to be determined by trial. The interested parties should agree to use a specified sieving time, as only in this way will their results be comparable.

If the end-point is decided by sieving rate, it is important to ensure that the rate is not being significantly reduced by blinding of the sieve apertures. In such cases, the underside of the sieving medium may be stroked *gently* with a soft brush periodically and the resulting dust added to the undersize material. On the other hand, if large quantities of dust are present in the test sample, a preliminary removal can be made. In this way, losses during testing and the adherence of dust to the sieve wires can be minimized.

The dust may be removed as follows. The finest sieve to be used in the test is fitted on a receiver pan, and the given sample is sieved through it for 5-10 minutes. Abrasion of wires of fine sieves by coarse particles can be prevented by first making the sample pass through a coarse screen. For example, a 500 micron aperture sieve can be used to protect a 100 micron sieve.

After de-dusting, the oversize fraction is transferred to the chosen nest of sieves and sieved in the approved manner as described above. The fines, which passed into the receiver pan, are added to the fines obtained in the main sieve test.

5.3.2 Machine Test Sieving

The above testing procedure of sieving by hand can be tedious and the accuracy of the method may also depend to a considerable extent on the operator who performs the test.

In machine sieving most of the burden is removed from the operator, and once the optimum conditions have been determined, reproducible results are rapidly obtained.

For example, the nest of sieves may be shaken for a certain predetermined time, e.g. 10 minutes, on the machine. Before recording the amount of material retained on each sieve it is recommended that the end-point test, described above in Section 5.3.1 is applied to ensure that the retained fraction contains virtually no undersize material.

In all cases where test sieving has been carried out on a mechanical test sieve shaker it is essential that, in reporting the results, the type of machine and time of sieving should be recorded.

Fig.5.1 Wet sieving with the aid of a test sieve shaker.

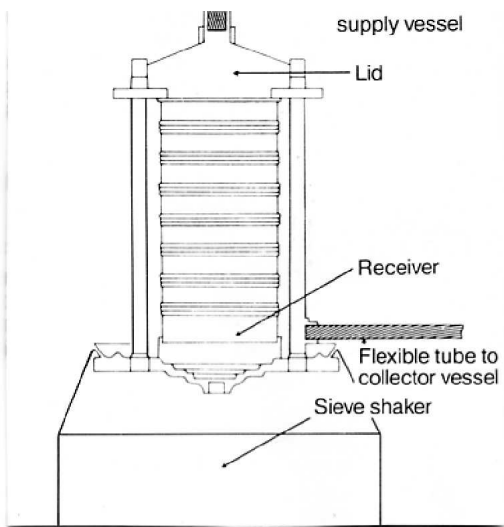

5.3.3 Wet Sieving

Most sieve tests are carried out under dry conditions and the procedures for those have been described above. There are, however, many instances where wet sieving, despite its attendant inconveniences, has a distinct advantage over dry sieving. For example, the material to be tested may already be suspended in a liquid. Solids in slurry form are often sized by wet screening.

Samples of wet solids, such as treated ores or chemical precipitates, frequently contain some very fine particles which constitute a slime. These samples cannot be dried before sieving because the slime would cake into hard lumps. Wet sieving affords an easy method for removing and sizing these fine particles. The de-slimed product can then be wet-sieved or dried and afterwards dry-sieved.

Some fine particles cannot be sieved easily under dry conditions. For instance, the sieve apertures may readily become blinded, or the particles may become electrostatically charged or 'ball-up' when sieving is attempted, or break-down under the shaking action. For many of these difficult cases wet sieving can often help.

Water is the liquid most frequently used in wet sieving. For substances that are naturally water-repellent, e.g. coal and sulphide ores, the addition of a non-foaming wetting or dispersing agent may be necessary. For substances that are soluble in water, other liquids such as methylated spirits, white spirit, carbon tetrachloride, etc. can be used. It is important to ensure that the liquid used in wet sieving does not affect the particles in any other way than to effect their dispersion.

A simple method for wet sieving using water is as follows. The sieve is held over a bowl and the weighed sample is washed on to the mesh. The sieve is lowered into the water and held horizontally near the surface. A gentle jiggling motion is then made until the fine particles cease to pass through the sieve.

The sieve is then inverted over another bowl and the oversize particles are back-washed into it. After allowing the particles to settle in the bowl, most of the water is decanted off, and the rest is evaporated gently in an air stream or in a low-temperature drying cabinet. This dried fraction of solids is then weighed and, if desired, dry-sieved. The percentage of fines in the original sample is most usually found by the difference in masses.

Another method consists of washing the test sample through a sieve, or through a nest of sieves, but it is essential to add the liquid slowly, regularly and at a very low pressure to avoid loss of material and damage to the sieving medium. This operation may be carried out with the aid of a suitably modified test sieving machine (see Figure 5.1) and sieves fitted with a specially designed lid and receiver.

The procedure is as follows. The sieves and receiver are mounted on the test sieve shaker with the flexible tube connected to the receiver outlet leading to a collector vessel. The weighed test sample is carefully mixed with a portion of the sieving liquid and then transferred to the surface of the top sieve. The special lid, containing the liquid dispersion nozzle, is tightly fitted to the sieve nest and connected by means of a flexible tube to the liquid supply vessel, located at a height of at least 50cm above the nozzle. Liquid is then fed to the sieve nest and the test sieve shaker started. The liquid feed rate should be sufficient to cover the sieving area adequately, but not excessive: *it should not, under any circumstances, exceed the liquid out-flow rate.*

When the liquid passing to the collector vessel flows clear, the sieving process may be considered complete. The test sieve shaker is stopped, the sieves are allowed to drain and the sieve nest is dismantled. Each sieve should be given a final rinse with clean sieving liquid before washing the retained particles on to a filter. The dried particles can then be weighed. The fine particles passing with the exit liquid to the collector vessel may be recovered by filtration and, if necessary, dried and weighed also.

5.3.4 Combined Wet and Dry Sieving

Samples that contain significant amounts of very fine particles may be difficult to wet sieve in accordance with the procedures outlined in Section 5.3.3 owing to particle agglomeration or because unacceptably large volumes of

suspension have to pass through the fine sieves. The dry sieving of such samples, however, may also be difficult. It may take an unacceptably long time to reach an end point, for example, because of sieve aperture binding. In such cases, a combination of wet and dry sieving may often be used with advantage.

Wet sieving is used first, following the procedures outlined in Section 5.3.3 to wash the undersize particles through the finest sieve in the chosen set. If necessary, this fine sieve may be protected from the damaging action of any coarse particles present by interposing one or more relatively large-aperture guard sieves.

One procedure for determining the mass of material passing through the finest sieve is to collect the washings and separate the suspended solids by filtration and subsequent drying. Flocculation of the suspended particles may assist filtration.

Alternatively, it may be preferable to determine the dry mass of the initial charge and then dry and weigh the combined oversizes from the washing stage. The mass of undersize is then determined as the difference between the initial and final masses.

In the subsequent dry sieving procedure, the combined oversize from the washing stage, as described above, is dried and sieved following the procedures outlined in Section 5.3.1 using the chosen set of sieves in which the finest sieve should have the same aperture as that used in the washing stage.

5.4 Cleaning and Maintenance of Test Sieves

It should always be remembered that a test sieve is a measuring instrument, and should not be maltreated. Sieves should be used with care, cleaned regularly and stored in a safe dry place. Endecotts cartons have been designed to act as storage containers.

Particles should not be forced through a test sieve. Even the gently brushing of material through the finer meshes is undesirable, but this procedure is occasionally unavoidable for certain materials that are otherwise difficult to sieve. If brushing is found necessary, care should be taken to avoid particle break-down. Sieves which are in constant use should be inspected regularly for mesh defects.

Sieves should be cleaned after each analysis and replaced in their storage containers. Most of the near-mesh particles, which block the sieve openings, can usually be removed by inverting the sieve and gently tapping the frame. The underside of the wire cloth may also be stroked gently with a soft brush, although great care must be taken to avoid damaging the mesh. Another method for removing entrapped particles, particularly from small-aperture sieves, is to shake the sieve upside-down on a sieving machine.

Occasionally sieves may be washed and the underside of the mesh stroked gently with a soft brush in warm water containing small amount of liquid synthetic detergent. The sieve should afterwards be rinsed thoroughly in clean water and dried quickly in a warm atmosphere. To avoid possible

mesh distortion the sieve should not be heated above 80°C. Sieves that have been used for wet sieving should not be allowed to dry-out before attempting to clean them because material caught in the mesh may become permanently trapped. Acid, alkaline or organic solvent cleaning is not recommended.

Sieves may also be cleaned by immersion in a suitable liquid in an ultrasonic bath and treated for 15 to 20 seconds with a frequency of not less than 30 kHz and power input not exceeding 60 W/L.

The above methods are usually quite suitable for keeping test sieves in good order without affecting their accuracy. Brass sieves are still commonly used, but care may have to be taken when sieving certain chemicals, especially hygroscopic salts, that the sieves are always washed clean and dried after each test.

For the sizing of substances which are liable to corrode brass we recommend the use of Stainless Steel sieves.

5.5 Micro Sieving

In recent years the test sieving technique has been extended down to about 5 microns by the use of instruments called microsieves.

One very popular type is the *micro-plate sieve* which is fabricated by electroetching or electroforming apertures in a nickel plate. The result is a series of very accurate round or square hole perforations with a unique self-clearing form which minimises blinding. These robust micro-plate sieves can withstand the intense vibrations produced, for example, in wet sieving with the aid of ultrasonic irradiation. Microsieves may be used for wet or dry sieving.

For dry sieving, conventional techniques may be used for sizes down to about 20 microns (see Section 5.3.2). For smaller aperture sizes, techniques such as the air jet method are usually necessary to allow particles to pass through the sieve apertures.

In wet sieving, the techniques of gently jiggling the sieve in a bowl of liquid (Section 5.3.3) may assist the passage of the particles through the apertures. Ultrasonic sieving can be effected by locating the sieving surface just under the surface of water, or other suitable liquid, in a glass beaker which in turn is placed in water in a conventional laboratory-size ultrasonic cleaning bath.

Section 6:

Data-Analysis

6.1 Tabulation of Data

There are several ways in which the results of a sieve test can be tabulated. The three most convenient methods are indicated together in Table 1 where a typical size analysis carried out with BS sieves is recorded.

First, the fractions retained on each of the sieves used in the test can be listed as percentages of the original test sample weight. This is probably the most widely used (but not necessarily the best) method recording sieve test data. A brief glance at the relevant column of Table 6.1 brings out such facts as (a) the largest fraction was retained between 850 and 600 micron sieves, and (b) the bulk of the material was confined to the 1180-300 micron range.

In the second and third tabular methods, the cumulative percentages (i.e., running totals) of oversize and undersize materials are listed. Either of these methods can be used to provide information not readily gathered from the fractional table. The percentages of material larger or smaller than a certain mesh size can be roughly estimated from cumulative tables.

For example, referring to Table 6.1, it can be seen that 72.7% of the material was finer than 850 microns and 83.0% was coarser than 300 microns. It can also be roughly estimated that the quantity that would have passed through a 500 micron sieve, is about 37% (arithmetic mean of 46.3 and 27.8; the quantities relating to the 600 and 425 micron apertures respectively).

Table 6.1 Tabulation of Sieve Test Data

Sieve Aperture (microns)	Weight Percentages		
	Retained	Cumulative Oversize	Cumulative Undersize
1700	1.1	1.1	98.9
1180	5.6	6.7	93.3
850	20.6	27.3	72.7
600	26.6	53.7	46.3
425	18.5	72.2	27.8
300	10.8	83.0	17.0
212	5.9	88.9	11.1
150	3.9	92.8	7.2
106	2.7	95.5	4.5

6.2 Graphical Methods

The full significance of a sieve test can most readily be assessed when the data are recorded in graphical form. Trends which are frequently obscured in a mass of figures in a table are easily seen in a graph. The extra effort involved in graphical plotting is usually rewarded by the additional amount of useful information obtained.

Graphical techniques are very useful aids for routine test sieving. It is much easier, for instance, to compare the data from several tests on one graph than it is by trying to compare tables of figures. Again, by the use of certain graphical techniques, described in Section 6.4, it is often possible to reduce the number of sieves used in a test to 2 or 3, with a subsequent and valuable saving in time and labour.

There are literally dozens of different graphical methods that are used, or have been suggested for use, in sieve test data analysis. The actual method to be chosen in any given

case will, of course, depend on the characteristics of the data and the sort of information that is required.

Only a few of the more common methods will be discussed here, and these involve the use of three different types of graph paper.

6.2.1 Ordinary, or squared graph paper

This is the most common graph paper of all. Both scales are marked off in a series of equal intervals. Other names for this type of paper are arithmetic and linear.

6.2.2 Semi-log graph paper

On semi-logarithmic graph paper one scale is marked off in equal intervals (arithmetic or linear scale) and the other on a logarithmic scale. On this latter scale the spacings between 1 and 10, 10 and 100, 100 and 1000 are the same. These intervals are called 'cycles' and usually 2-cycle paper will suffice for most tests. However, to cover the entire fine-mesh sieve range 3-cycle paper would be required.

6.2.3 Log-log graph paper

On log-log graph paper both scales are marked off logarithmically. For most test sieve analyses 2 x 2 cycle paper is used, but if full fine-mesh size range is to be covered, one 3-cycle scale is necessary.

Some of the uses of the above types of graph paper will now be described briefly. For illustration purposes the same test data (Table 6.1) are used in every case. It must be understood, however, that all the methods described here will not necessarily be applicable to any given set of data. Experience will determine the best graphical method for any particular case.

6.3 Fractional Percentage Graphs

The retained fractions listed in Table 6.1 may be plotted on ordinary (squared) or semi-log graph paper, either in the form of histograms (bar charts) or as frequency curves. With any of these methods an immediate picture of the size distribution is obtained as shown in Figures 6.1 and 6.2. In this case, a sharp peak is seen in the 850-600 micron region, and the extent of the size spread is clearly visualized.

The widths of the vertical columns of the histograms extend between the various adjacent sieves used in the test. The points on the frequency curves are plotted in between two sieve sizes. For example, for the peak fraction, which passed through an 850 micron sieve and was retained on a 600 micron sieve, the mean particle size could be taken as the average of 850 and 600 = 725 microns.

The main virtue of the plot on ordinary or squared graph paper (Figure 6.1) is simplicity; the main disadvantage is that points in the region of the smaller aperture sizes tend to become congested. For instance, the data in Table 6.1 were obtained from alternate sieves in the BS range, but if consecutive sieves had been used, some of the points would have crowded into one another on the graph.

Congestion is avoided on the semi-logarithmic plot (Figure 6.2) The points in the small aperture size region are spread out and those in the coarse mesh region closed up, with the result that the points are approximately equidistant and the columns of the histogram are approximately of equal widths.

6.4 Cumulative Percentage Graphs

Cumulative percentages of oversize or undersize material plotted against sieve aperture size give graphs of wide applicability. Figure 6.3 demonstrates the use of both ordinary and semi-log graph paper for this purpose. In both cases it can be seen that the oversize and undersize curves are actually mirror images of one another. They cross-over at 50 cumulative per cent. For most practical purpose, only one of these curves need be plotted.

As described above for the fractional percentage graphs, the main advantage of the arithmetic plot is simplicity, and the main advantage of the semi-log plot is the avoidance of congestion of the points in the small aperture size region. One of the principle uses of graphs such as those shown in Figures 6.3a and 6.3b is for predicting values that were not measured experimentally, i.e., for interpolation between the recorded points.

For example, although a 500 micron aperture sieve was not used in the test (Table 6.1) it is easily ascertained from Figure 6.3b that about 37% of the sample would have passed through such a sieve.

Another valuable quantity readily obtained from graphs such as those shown in Figure 6.3 is the median size of the sample. This defines the mid -point in the size distribution; half the particles are smaller than the median size and half are larger. The median size therefore, is read off either graph corresponding to 50% oversize or undersize. In this case the median size is 640 microns.

An extremely useful cumulative plot can be made on log-log graph paper. Cumulative undersize data are plotted against sieve aperture in Figure 6.4. The oversize curve is of no value; it is not a mirror image of the undersize curve.

The interesting point here is that a log-log cumulative undersize plot very frequently results in a straight line over a wide size range, particularly over the smaller sizes. In Figure 6.4 for example, the straight line extends over the region 850 to 105 microns. Interpolation is much easier from a straight line than it is from a curve. Thus, if it is known that data obtained from the material being tested usually yield a straight line plot, the burden of routine analysis can be greatly eased. For example for the case shown in Figure 6.4 only 2 sieves need have been used (e.g. 600 and 150 micron sieves) to check essential features of the size distribution.

The median size of the material (640 microns) can be read off at 50% undersize on a log-log plot in the same manner as described for the semi-log plot.

6.5 Precision of Weighing

The fraction quantities retained on the sieves and the undersize should be weighed with a precision of $\pm 0.1\%$ of the mass of the charge. The sum of these masses should not differ by more than 2% from that of the test sample mass. The losses are to be recorded separately.

The fraction masses should be converted into percentages of the sum total of the fraction masses collected not of the original test sample mass.

6.6 Reproducibility

The reproducibility of results, i.e., the permissible differences between two independent analyses, should be specified in the relevant Standard for the particular product or by the interested parties.

Section 7: Particle Size

7.1 Equivalent Diameters

The exact size of an irregular particle cannot be measured. The terms length, breadth, thickness or diameter have little meaning because so many different values of these quantities can be determined. However, it is frequently desirable to quote the size of a particle in terms of a single quantity, and the expression most often used is the 'equivalent diameter'. This refers to the diameter of a sphere that would behave in the same manner as the particle when submitted to some specified operation.

Several equivalent diameters are commonly encountered. For example, the *Stokes' diameter* is measured by sedimentation and elutriation techniques; the *projected area diameter* is measured microscopically, and the *sieve aperture diameter* is measured by means of test sieving. For any given irregular particle the magnitudes of these three 'diameters' will not be equal.

The equivalent sieve aperture diameter of a particle is the diameter of a sphere equal to the width of the aperture through which the particle just passes. If the particles being tested are not true spheres, and they rarely are in practice, this equivalent diameter refers only to their second largest dimension.

Recorded data from any size analysis should, where possible, be accompanied by some remarks which indicate the approximate shape of the particles. Descriptions such as 'granular', 'slightly elongated' or 'long needles', are usually quite adequate to convey the approximate shape of the particle in question. However, for more precise work the particle shape may be evaluated in terms of shape factors (see Section 7.4).

7.2 Powder Types

It is fairly common practice to talk about ‘fine’ and ‘coarse’ particulate substances, but these terms are only relative. Fine sand, for instance, would normally represent much larger particles than say fine flour.

An attempt was made in BS 2955 (Glossary of terms relating to powders) to standardize particle nomenclature in certain fields. It is recognised, however, that these descriptions will not necessarily be suitable for all purposes. For describing pharmaceutical powders the gradings suggested in the British Pharmacopœia, shown in Table 7.1 can be used.

Table 7.1 Terms used in the British Pharmacopœia for describing powdered materials

Powder Type	All passes		Not more than 40% passes	
	Mesh No.	Microns	Mesh No.	Microns
Coarse	10	1700	44	355
Moderately Coarse	22	710	60	250
Moderately fine	44	355	85	180
Fine	85	180	120	125
Very fine	120	125	350	45

When discussing particle sizes in terms of sieve mesh numbers, it often helps if some particulate substances can be visualized. For example, the approximate median size ranges (50% of the material is larger than the median) of a few common household commodities are given in Table 7.2.

Table 7.2 Approximate ranges of the median sizes of some common household commodities

Commodity	BS Mesh	Microns
Rice and barley grains	6-8	2800-2000
Granulated sugar	30-44	500-355
Table salt	52-72	300-210
Cocoa	200-300	75-53
Iceing sugar	300-350	53-45

7.3 Limiting and Mean Sizes

Just as it is desirable to assign a size or ‘diameter’ to one irregular particle, it is likewise advantageous to apply a simple description to a polysize sample, i.e., a mass of particles of different sizes. A large number of these grading terms are available, and whilst their choice is largely a matter of personal selection, several do have specific uses.

Crushed coal and coke, for instance, are frequently classified according to the Upper Sieve Size. This is defined as the sieve mesh through which 99% of the material passes. On the other hand, sand and gravel, especially those grades used for filter beds, are often classified according to the Effective Size. This is defined as the sieve mesh on which 90% of the material is retained.

The Median Size is a useful quantity for general grading purposes. Fifty per cent of the material is smaller than the median size and 50% is larger. Upper-sieve, effective and median sizes are most readily obtained by the cumulative graphical techniques described in Section 6.

In addition to these three classifications, a large number of different average or mean diameters are employed for describing polysize particulate masses. Four of the most common of these may be expressed as follows:

$$\text{Arithmetic mean: } d_a = \frac{1}{2} (d_1 + d_2)$$

$$\text{Geometric mean: } d_g = \sqrt{d_1 d_2}$$

$$\text{Volume mean: } d_v = \frac{\sum wd}{\sum w}$$

$$\text{Surface mean: } d_s = \frac{\sum w}{\sum (w/d)}$$

where:

d_1 = sieve aperture through which the particles pass.

d_2 = sieve aperture on which the particles are retained.

w = mass of particles in a fraction with an arithmetic mean size d_a

Σ = the summation symbol.

The arithmetic mean diameter d_a is the simplest to use, but it is only really applicable when the two sieves concerned (i.e. sizes d_1 and d_2) are close together. The geometric mean is sometimes preferred for close sieves; it gives a smaller value than the arithmetic mean.

For example, if the particles have passed through a 700 micron sieve and been retained on a 500 micron sieve then:

$$d_a = \frac{1}{2}(700 + 500) = 600$$

microns. and

$$d_g = \sqrt{(700 \times 500)} = 591 \text{ microns.}$$

The volume mean diameter d_v , which is also sometimes referred to as an arithmetic mean, is commonly used to arrive at a mean size of a polysize sample. The surface mean diameter d_s is similarly used and is of particular value when the surface area of the particles is an important property.

The calculation of d_v and d_s values may be demonstrated from the sieve test data recorded in Table 7.3 as follows:

$$\text{Volume mean } d_v = \frac{\sum wd}{\sum w} = \frac{39}{100} \times 130 = 391 \text{ microns}$$

$$\text{Surface mean } d_s = \frac{\sum (w/d)}{\sum (w/d)} = \frac{0.2959}{0.2959} \times 338 = 338 \text{ microns}$$



Table 7.3 Calculation of volume and surface mean diameters from sieve test data

Aperture (microns)	Aperture Mean d	Per cent Retained w	wd	w/d
850				
600	725	11.8	8 570	0.0163
425	512	18.6	9 500	0.0364
300	362	38.5	13 800	0.1072
212	256	22.7	5 740	0.0896
150	181	8.4	1 520	0.0464
Totals	Σ	100	39 130	0.2959

7.4 Particle Shape

No particle sizing technique, test sieving included, can fully characterize particles without additional information on the particle shape. For example, a sphere of diameter d could pass through a sieve aperture of width d , but so could a cylinder of diameter d and length l , where l could be larger or smaller than d . However, from the sieving point of view, both particles would be characterized by the same size d . It is useful, therefore, to be able to evaluate the shape of a particle and to express this quantity in a simple manner. This can be done with the aid of ‘shape factors’.

For example, the volume v and surface area s of a particle may be expressed in terms of its characteristic size d by the relationships:

$$v = f_v d^3$$

$$s = f_s d^2$$

Where f_v and f_s are called the volume and surface shape factors respectively.

For spherical particles of diameter $= d$:

$$f_v = \pi/6 = 0.524$$

$$\text{and } f_s = \pi = 3.14$$

For cubes with length of side $= d$:

$$f_v = 1 \text{ and } f_s = 6.$$

Shape factors are readily calculated for other regular geometrical solids. For an octahedron, for example, with d representing the length of an edge,
 $v = \sqrt{2} d^3/3$ and $s = 2\sqrt{3} d^2$ and therefore,

$$f_v = \sqrt{2}/3 = 0.471$$

$$f_s = 2\sqrt{3} = 3.46$$

The surface:volume ratio is also a useful property of particulate matter for particles of size d

$$\frac{s}{v} = \frac{f_s d^2}{f_v d^3} = \frac{F}{d}$$

$$v = f_v d^3 \quad d$$

The constant $F(= fs/fv)$ is called the ‘overall shape factor’. For spheres and cubes, $F = 6$. For other shapes, $F > 6$, e.g. for an octahedron $F = 7.35$. Values of F around 10 are frequently encountered in comminuted solids and much higher values may be found for elongated or flaky particles.

Section 8:

Industrial Screening

8.1 Sieving and Screening

Particulate solids are generally required in graded sizes. This applies to raw materials, e.g. sand, gravel or ore, as well as to finished products, e.g. crystalline chemicals. Screening processes are consequently employed in a very wide range of industries. The object of a screening process is to make a ‘cut’ in the feedstock material. For example, to remove the ‘roughs’ and ‘fines’, or to produce a close-sized fraction of material for sale or subsequent use.

Screening on an industrial scale is quite a different operation from the laboratory procedures for test sieving described in Section 5. In test sieving the separation process is continued to an end point, i.e. until no more, or very little, of the material passes through the given sieve. In industrial screening there is neither the time, nor indeed the necessity, to approach this degree of perfection.

The industrial screening process is usually a continuous one. Feed material flows at a steady rate on to the shaking or vibrating screen and remains on the screening surface for a relatively short time. The passage of particles through the screen apertures is impeded by the motion of the screen and by the presence of the other particles. The particle interference, coupled with the short residence time on the screen, leads to an imperfect separation.

8.2 Screening Efficiency

The material fed to a screen can be considered to be composed of two parts, an oversize fraction consisting of particles that are too large to pass through the screen apertures, and an undersize fraction consisting of particles that are too small to be retained on the screen. The screening efficiency, or effectiveness of separation, therefore, should indicate the degree of success obtained on the segregation of these two fractions.

As explained above, a ‘clean’ separation is never achieved in an industrial screening operation. Undersize particles are

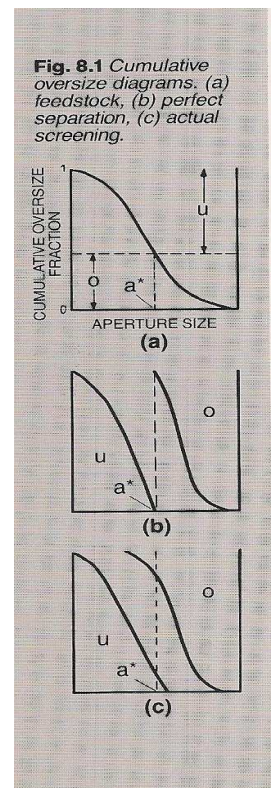

Fig. 8.1 Cumulative oversize diagrams. (a) feedstock, (b) perfect separation, (c) actual screening.

invariably left in the oversize fraction, mainly because the material does not remain on the screen for a sufficiently long period. Oversize particles may be found in the undersize fraction if the screen mesh is non-uniform, punctured or inadequately sealed around its edges.

There is no generally accepted definition of the term 'efficiency' applied to a screening process. Various industries adopt the one which most simply and adequately meets their needs. The following analysis indicates a few of the expressions commonly employed.

Figure 8.1a gives the sieve analysis of the feed material, plotted as a cumulative oversize fraction versus the sieve aperture as explained in Section 6. Therefore, for an effective screen aperture, a^* , fraction O represents the oversize particles and fraction U represents the undersize. For a perfect separation, the sieve analyses of these two fractions would be as shown in Figure 8.1b, no particles smaller than a^* appear in the oversize fraction, and no particles larger than a^* appear in the undersize fraction. In practice, however, unwanted particle sizes do appear in the undersize and oversize flowstreams (Figure 8.1c).

A screening operation separates a feedstock, F into an oversize top product, O , and an undersize bottom product, U , as indicated in the sketch below:

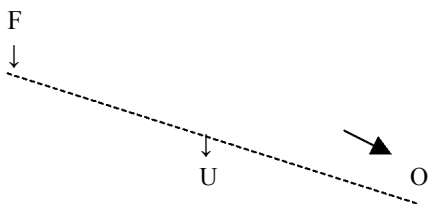

If F , O , and U represent the mass flows of these streams, an overall balance on the process gives

$$F = O + U \dots \dots \dots (1)$$

and a balance on the oversize material gives

$$F x_F = O x_O = U x_U \dots \dots \dots (2)$$

where x_F , x_O and x_U are the fractions of true oversize material,

For perfect screening

$$O x_O = F x_F \dots \dots \dots (3)$$

In other words, all the oversize material present in the feedstock ends up in the overflow stream. Similarly, all the undersize material should end up in the overflow stream in an ideal process.

For actual screening, two efficiencies can be defined. Firstly, an efficiency E_1 which gives a measure of the

success of recovering oversize particles in the overflow stream:

$$E_1 = \frac{O x_O}{F x_F} \dots \dots \dots (4)$$

and the other E_2 , which relates to the recovery of undersize material in the underflow stream:

$$E_2 = \frac{U(1 - x_U)}{F(1 - x_F)} \dots \dots \dots (5)$$

For the complete screening operation, therefore, an overall screen efficiency, E , can be defined as the product of these two efficiencies, i.e.

$$E = E_1 E_2 \dots \dots \dots (6)$$

8.3 Sample Calculation

The application of these equations is best demonstrated by an actual example. The data in Table 8.1 were obtained on an actual screening process in which the effective screen aperture (the 'cut' size) was 460 microns and the flow rates of the various streams were $F = 1000$, $O = 650$, and $U = 350$ kg/h respectively.

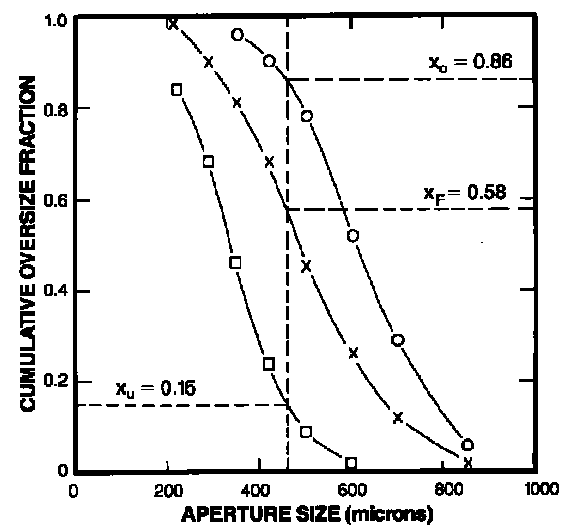

Fig.8.2 Calculation of the screening efficiency

The sieve analyses for the three streams are plotted in Figure 8-2 where it can be seen that the values of x_f , x_o and x_u at the 'cut' size are 0.58, 0.86 and 0.15 respectively.

$$E_1 = \frac{650(0.86)}{1000(0.58)} = 0.964$$

$$E_2 = \frac{350(1 - 0.15)}{1000(1 - 0.58)} = 0.708$$

and the overall efficiency $E = 0.964 \times 0.708 = 0.68$ or 68%

Table 8.1 Sieve analysis of the various flow streams in a screening process

Sieve Aperture Size (microns)	Cumulative Oversize Weight Fraction		
	Feedstock	Overflow	Underflow
850	0.02	0.06	
710	0.12	0.29	
600	0.26	0.52	0.02
500	0.45	0.78	0.09
425	0.68	0.80	0.24
355	0.81	0.96	0.46
300	0.90	1.00	0.68
212	0.98		0.84
	1.00		1.00

The difference between a perfect and an actual screening operation is shown diagrammatically in Figure 8.1.

Worldwide Applications

Industry	Applications
Construction	Quality Control Analysis and Grading of Soils, Aggregate, Minerals, Cement etc
General Laboratories	Miscellaneous application of particle analysis and determination of particle size, Powder Process Industries etc.
Chemical and Pharmaceutical	Oil Exploration (analysis of minute fossils) , Fuels , Explosives, Drugs, Medical & Pharmaceutical applications.
Mining	Quarries (Gravel and Sand), Coal Mines (Air pollution control), Grading and Particle Size Determination, Diamond Mines, Grading of Diamonds and Industrial Diamonds.
Agriculture / Food	Confectionery and Food Manufacture, Miscellaneous Applications including kernals etc.
Education	Schools , Universities (training of techniques in particle size analysis and determination of particle size). Geological etc.
Research	Research establishments engaged in original and general research.
Engineering	Steel Manufacturing Organisations , Foundries, Iron Works, etc. (Determination of particle size of sand moulds, grading of coke, etc)
Abrasive Grain Industries	Producers of precision materials for abrasive applications, i.e. grinding wheels and sandpaper.



General Laboratory



Agriculture/Food



Research



Engineering



Mining

SPECIFICATIONS

A table of the most widely used specifications

International Test Sieve Series ISO 3310:2000		British Standard Sieve Series BS.410:2000		American Standard Sieve Series ASTM E11:01	
Wire Mesh Series		Wire Mesh Series		Perforated Plate Series	
ISO 3310-1:2000 BS410-1:2000		ISO 3310-1:2000 BS410-1:2000		ISO 3310-1:2000 BS410-1:2000	
Nominal Aperture Sizes		Nominal Aperture Sizes		Nominal Aperture Sizes	
mm		microns		Round & Square Holes mm	
125.00	900	125.00	900	125.00	4.75
112.00	850	112.00	850	112.00	4.50
106.00	800	106.00	800	106.00	4.25
100.00	710	100.00	710	100.00	4.00
90.00	630	90.00	630	90.00	3.75
80.00	600	80.00	600	80.00	3.50
75.00	560	75.00	560	75.00	3.25
71.00	500	71.00	500	71.00	3.00
63.00	450	63.00	450	63.00	2.75
56.00	425	56.00	425	56.00	2.50
53.00	400	53.00	400	53.00	2.25
50.00	355	50.00	355	50.00	2.00
45.00	315	45.00	315	45.00	1.75
40.00	300	40.00	300	40.00	1.50
37.50	280	37.50	280	37.50	1.25
35.50	250	35.50	250	35.50	1.00
31.50	224	31.50	224	31.50	0.75
28.00	212	28.00	212	28.00	0.50
26.50	200	26.50	200	26.50	0.25
25.00	180	25.00	180	25.00	0.125
22.40	160	22.40	160	22.40	0.075
20.00	150	20.00	150	20.00	0.05
19.00	140	19.00	140	19.00	0.0375
18.00	125	18.00	125	18.00	0.025
16.00	112	16.00	112	16.00	0.0175
14.00	106	14.00	106	14.00	0.0125
13.20	100	13.20	100	13.20	0.00875
12.50	90	12.50	90	12.50	0.00625
11.20	80	11.20	80	11.20	0.0045
10.00	75	10.00	75	10.00	0.00325
9.50	71	9.50	71	9.50	0.00225
9.00	63	9.00	63	9.00	0.00175
8.00	56	8.00	56	8.00	0.00125
7.10	53	7.10	53	7.10	0.000875
6.70	50	6.70	50	6.70	0.000625
6.30	45	6.30	45	6.30	0.00045
5.60	40	5.60	40	5.60	0.000325
5.00	38	5.00	38	5.00	0.000225
4.75	36	4.75	36	4.75	0.000175
4.50	32	4.50	32	4.50	0.000125
4.00	25	4.00	25	4.00	0.0000875
3.55	20	3.55	20	3.55	0.0000625
3.35		3.35		3.35	0.000045
3.15		3.15		3.15	0.0000325
2.80		2.80		2.80	0.0000225
2.50		2.50		2.50	0.0000175
2.36		2.36		2.36	0.0000125
2.24		2.24		2.24	0.00000875
2.00		2.00		2.00	0.00000625
1.80		1.80		1.80	0.0000045
1.70		1.70		1.70	0.00000325
1.60		1.60		1.60	0.00000225
1.40		1.40		1.40	0.00000175
1.25		1.25		1.25	0.00000125
1.18		1.18		1.18	0.000000875
1.12		1.12		1.12	0.000000625
1.00		1.00		1.00	0.00000045
					0.000000325
					0.000000225
					0.000000175
					0.000000125
					0.0000000875
					0.0000000625
					0.000000045
					0.0000000325
					0.0000000225
					0.0000000175
					0.0000000125
					0.00000000875
					0.00000000625
					0.0000000045
					0.00000000325
					0.00000000225
					0.00000000175
					0.00000000125
					0.000000000875
					0.000000000625
					0.00000000045
					0.000000000325
					0.000000000225
					0.000000000175
					0.000000000125
					0.0000000000875
					0.0000000000625
					0.000000000045
					0.0000000000325
					0.0000000000225
					0.0000000000175
					0.0000000000125
					0.00000000000875
					0.00000000000625
					0.0000000000045
					0.00000000000325
					0.00000000000225
					0.00000000000175
					0.00000000000125
					0.000000000000875
					0.000000000000625
					0.00000000000045
					0.000000000000325
					0.000000000000225
					0.000000000000175
					0.000000000000125
					0.0000000000000875
					0.0000000000000625
					0.000000000000045
					0.0000000000000325
					0.0000000000000225
					0.0000000000000175
					0.0000000000000125
					0.00000000000000875
					0.00000000000000625
					0.0000000000000045
					0.00000000000000325
					0.00000000000000225
					0.00000000000000175
					0.00000000000000125
					0.000000000000000875
					0.000000000000000625
					0.00000000000000045
					0.000000000000000325
					0.000000000000000225
					0.000000000000000175
					0.000000000000000125
					0.0000000000000000875
					0.0000000000000000625
					0.000000000000000045
					0.0000000000000000325
					0.0000000000000000225
					0.0000000000000000175
					0.0000000000000000125
					0.00000000000000000875
					0.00000000000000000625
					0.0000000000000000045
					0.00000000000000000325
					0.00000000000000000225
					0.00000000000000000175
					0.00000000000000000125
					0.000000000000000000875
					0.000000000000000000625
					0.00000000000000000045
					0.000000000000000000325
					0.000000000000000000225
					0.000000000000000000175
					0.000000000000000000125
					0.0000000000000000000875
					0.0000000000000000000625
					0.000000000000000000045
					0.0000000000000000000325
					0.0000000000000000000225
					0.0000000000000000000175
					0.0000000000000000000125
					0.00000000000000000000875
					0.00000000000000000000625
					0.0000000000000000000045
					0.00000000000000000000325
					0.00000000000000000000225
					0.00000000000000000000175
					0.00000000000000000000125
					0.000000000000000000000875
					0.000000000000000000000625
					0.00000000000000000000045
					0.000000000000000000000325
					0.000000000000000000000225
					0.000000000000000000000175
					0.000000000000000000000125
					0.0000000000000000000000875
					0.0000000000000000000000625
					0.000000000000000000000045
					0.0000000000000000000000325
					0.0000000000000000000000225
					0.0000000000000000000000175
					0.0000000000000000000000125
					0.00000000000000000000000875
					0.00000000000000000000000625
					0.0000000000000000000000045
					0.00000000000000000000000325
					0.00000000000000000000000225
					0.00000000000000000000000175
					0.00000000000000000000000125
					0.000000000000000000000000875
					0.000000000000000000000000625
					0.00000000000000000000000045
					0.000000000000000000000000325
					0.000000000000000000000000225
					0.000000000000000000000000175
					0.000000000000000000000000125
					0.0000000000000000000000000875
					0.0000000000000000000000000625
					0.000000000000000000000000045
					0.0000000000000000000000000325
					0.0000000000000000000000000225
					0.0000000000000000000000000175
					0.0000000000000000000000000125
					0.00000000000000000000000000875
					0.00000000000000000000000000625
					0.0000000000000000000000000045
					0.00000000000000000000000000325
					0.00000000000000000000000000225
					0.00000000000000000000000000175
					0.00000000000000000000000000125
					0.000000000000000000000000000875
					0.000000000000000000000000000625
					0.00000000000000000000000000045
					0.000000000000000000000000000325
					0.000000000000000000000000000225
					0.000000000000000000000000000175
					0.000000000000000000000000000125
					0.0000000000000000000000000000875
					0.0000000000000000000000000000625
					0.000000000000000000000000000045
					0.0000000000000000000000000000325
					0.0000000000000000000000000000225
					0.0000000000000000000000000000175
					0.0000000000000000000000000000125
					0.00000000000000000000000000000875
					0.00000000000000000000000000000625
					0.0000000000000000000000000000045
					0.00000000000000000000000000000325
					0.00000000000000000000000000000225

Sieve Diameters and Frame Materials

Diameter	Height	Depth to Mesh or	Frame Material
38	Full	19mm	Br or
100	Full	40mm	Br or
100	Half	20mm	Br or SS
300	Half	40mm	Br,SS Br,SS or PS
8 in	Full	2 in	Br,SS
8		1	Br or SS Br

Certification

Endecotts test sieves can be supplied to a variety of different inspection levels depending on the information requirements specified.

Certified Test Sieves	All test sieves manufactured to a National or International Specification are supplied with a Certificate of Compliance and individually serial numbered to provide full traceability.
Inspected Test Sieves	Test Sieves inspected in accordance with the procedures listed in clause 5.2 column 2 & 3 of ISO 3310: BS: 410-1:2000 table shown above. Each sieve is supplied with an Inspection Certificate stating separately the values for the average aperture in both the warp and weft direction of the wirecloth.
Mid Point Sieves	Test sieves with the sieving medium specification tolerances reduced by 30%. Each sieve is supplied with a Calibration Certificate giving the range of tolerances and measurements taken.
Calibrated Test Sieves	Test sieves inspected and calibrated in accordance with procedures listed in clause 5.2, column 4 & 5 of ISO 3310: BS: 410-1:2000. Each sieve is supplied with a calibration certificate recording the number of aperture and wire diameters measured, the average aperture size and standard deviation separately for the warp and weft direction. The type of weave will also be stated.
Matched Sieves	Two or more test sieves each fitted with a sieving medium having similar aperture characteristics. Each is supplied with a Calibration Certificate marked "Matched with sieve serial No....."
Re-Inspection Service	Used sieves are examined and inspected in accordance with the appropriate specification. Complying sieves are issued with a Compliance, Inspection or Calibration Certificate as requested by the customer.

Section 10:

Tables of Useful Data

The International System of Units (SI)

The international metric system (SI) has been adopted by the International Organisation for Standardization (ISO) and recommended by all national standards organisations. Much has been written about SI units in recent years and it is not the present intention to add to that literature. For an account of the background and specified uses of SI units readers are referred to the informative British Standard publications BS 3763 (1976) (The international system of units – SI) and PD 5686 (1978) (The use of SI units).

How to use SI Units

The SI is a rationalised selection of units in the metric system which individually are not new. There are six basic units (Table 10.1) and several derived units are merely for convenience and they can all be expressed, if desired, in terms of the basic units. A few derived units without special names are given in Table 10.3. Some SI units are of inconvenient size but the use of multiplying prefixes overcomes this difficulty. A list of the internationally agreed prefixes is given in Table 10.4.

Great care should be taken in the use of these prefixes. For example, the prefix should always be written immediately adjacent to the unit to be qualified, e.g. meganewton (MN) kilojoule (kJ), microsecond (μs), and so on. The primary units on the other hand, should be spaced apart, e.g. N s/m^2 or kg/ s m^2 . Only one prefix can be applied to a given unit at any one time; thus, one thousand kilograms (the ‘tonne’) is 1 megagram (Mg) and not 1 kilo-kilogram.

The symbol m stands for the basic unit ‘metre’ and the prefix ‘milli’, so to avoid confusion it has to be used very carefully in certain circumstances. For example, mN stands for millinewton while m N denotes the metre-newton. However, convention of spacing the basic unit is probably not sufficient safeguard in this case, so for the sake of clarity it is better to write the metre as the second unit, i.e. Newton-metre (N m).

Another important point to be noted is that when a multiple of a basic unit is raised to a power, the power applies to the whole multiple and not the basic unit alone. Thus 1 km^2 means $1 (\text{km})^2 = 10^6 \text{ m}^2$ and not $1 \text{ k}(\text{m})^2 = 10^3 \text{ m}^2$.

Not all the prefixes in Table 10.4 will come into common usage. Indeed there is much to be said for the suggestion to confine the choice of prefixes to those powers of 10 which are multiples of ± 3 , e.g. μ , m, k, etc. There is also some support for the use of ‘strict’ SI units, i.e. m, kg, s, in scientific publications and to write the power of ten in full, e.g. $3 \times 10^{-6} \text{ m s}^{-1}$ rather than $3 \mu\text{m s}^{-1}$.

The Advantages of SI Units

Although the SI is simply a development of the metre-kilogram-second (MKS) system, it is superior to MKS because it is a coherent system of units. By this is meant that the product or quotient of unit quantities in SI yield a unit resultant quantity (e.g. $1 \text{ N} \times 1 \text{ m} = 1 \text{ J}$ or $1 \text{ kg} \times 1 \text{ m} \div 1 \text{ s}^2 = 1 \text{ N}$). No numerical factors are involved, such as 4π which crops up in electrical technology if irrational definitions of basic units are used, or g which tends to appear unexpectedly in relationships which employ the gravitational unit of force.

SI units do not eliminate g , but they do relegate it to its proper place, i.e. to situations where the force of gravity is actually involved. For example, the SI unit of force is the Newton, defined as the force required to impart an acceleration of 1 m/s^2 to a mass of 1 kg. Thus the weight of a mass m kilograms is a force of mg newtons, where $g(\text{m/s}^2)$ is the local value of the acceleration due to gravity. As a matter of fact a Newton is just about the weight of an apple.

Table 10.1 The Basic SI Units

Quantity	Name of Unit	Unit Symbol
Length	metre	m
Mass	kilogram	kg
Time	second	s
Electric current	ampere	A
Thermodynamic temperature	kelvin	K
Amount of substance	mole	mol
Luminous intensity	candela	cd

Note. Temperature difference is commonly expressed in degrees Celsius instead of kelvins, but the unit for the Celsius and Kelvin scales is the same : $1 \text{ deg C} = 1 \text{ K}$.

Table 10.2 Some Derived SI Units Having Special Names

Physical Quantity	SI Unit	Unit	Symbol
Force	newton	N	= kg m/s^2
Pressure	pascal	Pa	= N/m^2
Work, energy, quantity of heat	joule	J	= N/m
Power	watt	W	= J/s
Electrical charge	coulomb	C	= A s
Electrical potential	volt	V	= W/A
Electric capacitance	farad	F	= A s/V
Electric resistance	ohm	Ω	= V/A
Frequency	hertz	Hz	= s^{-1}
Magnetic flux	weber	Wb	= V s
Magnetic flux density	tesla	T	= Wb/m^2
Inductance	henry	H	= V s/A
Luminous flux	lumen	lm	= cd sr^*
Illumination	lux	lx	= lm/m^2



Endecotts Ltd, 9 Lombard Road, London SW19 3TZ England
Tel : +44 (0) 20 8542 8121 Fax : +44 (0) 02 8543 6629
E-mail: sales@endecotts.com www.endecotts.com

E & E O

Endecotts endeavour to provide up to date and accurate information and guidance with respect to Test Sieving. This electronic document is constantly being revised and updated and therefore may not always contain the most current methods, technical data or technical information.